

# maxilift 4400 cobra

4400L (20 ft)

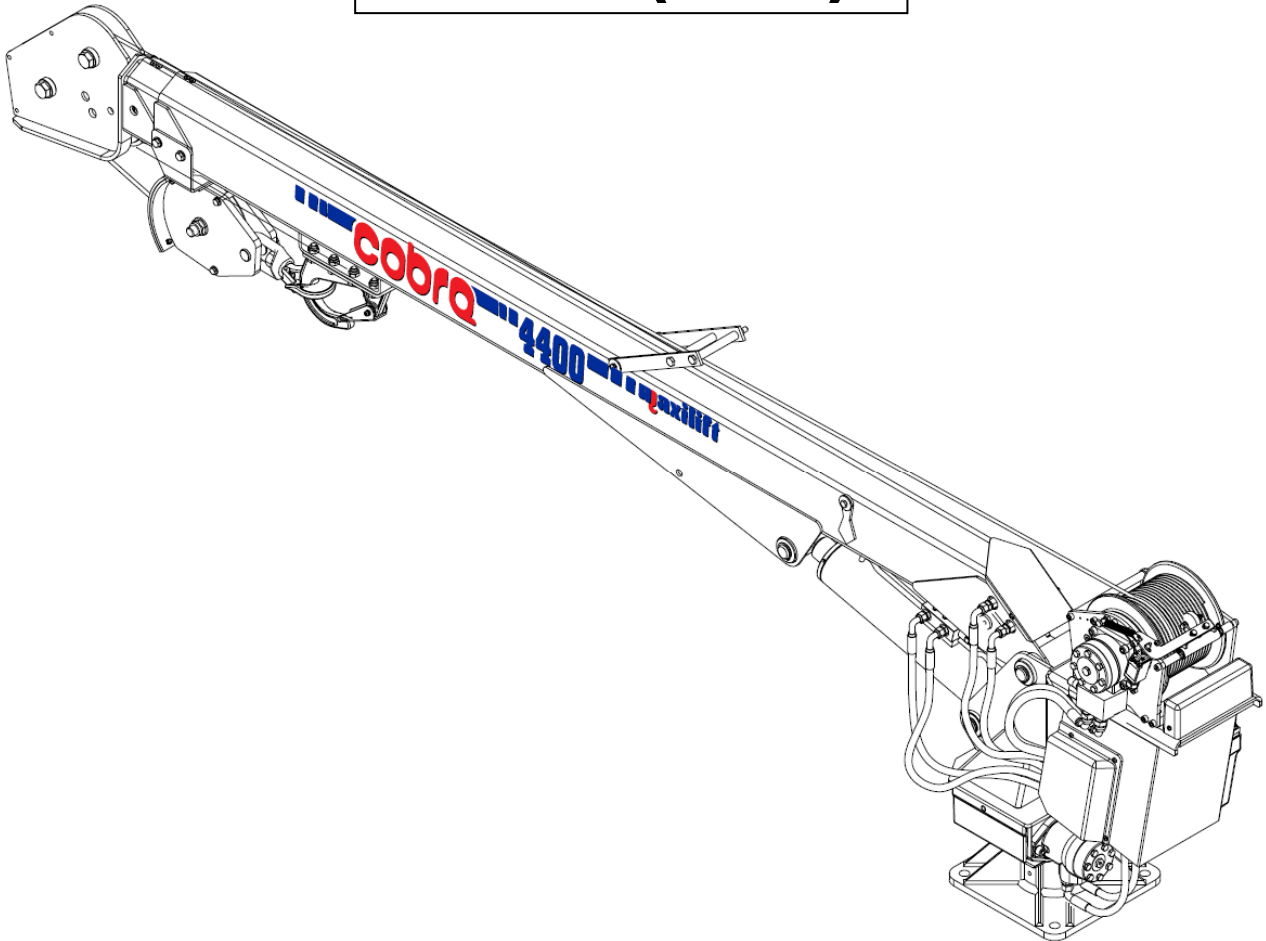

## TECHNICAL SHEET

MP.0.204  
Rev. 0



**Next Hydraulics**<sup>®</sup>  
RAISE YOUR EXPECTATIONS

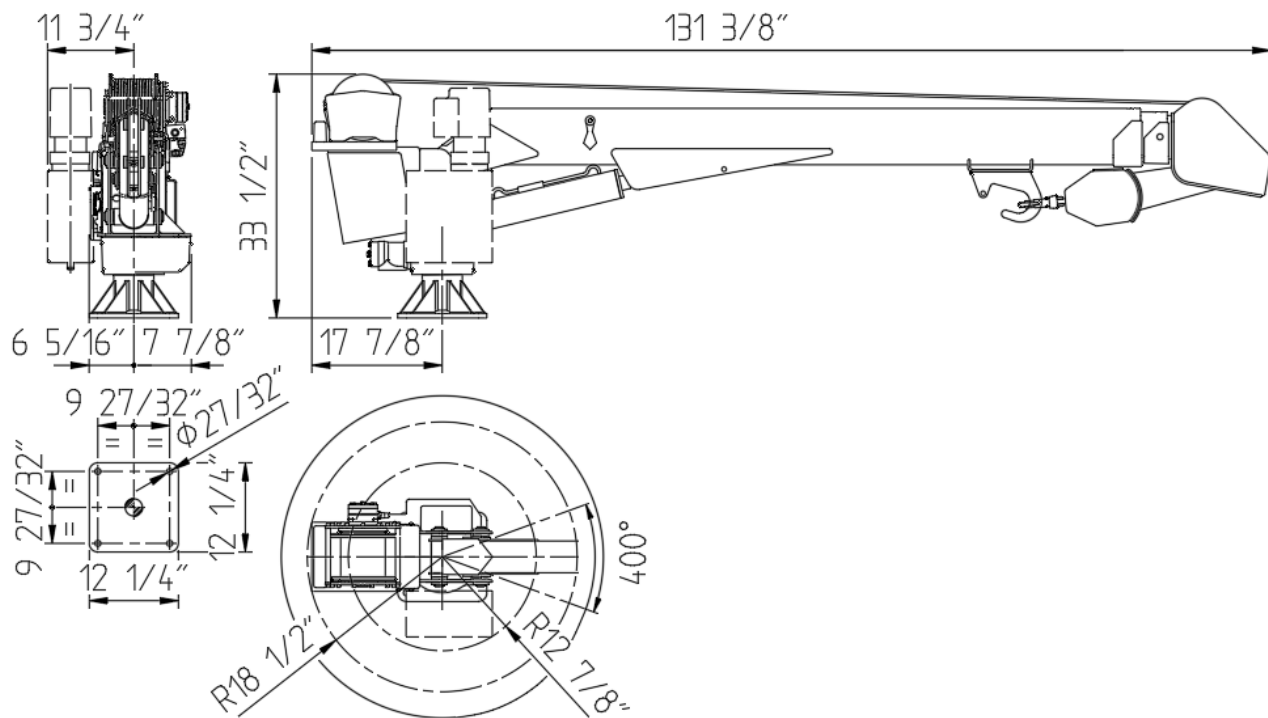
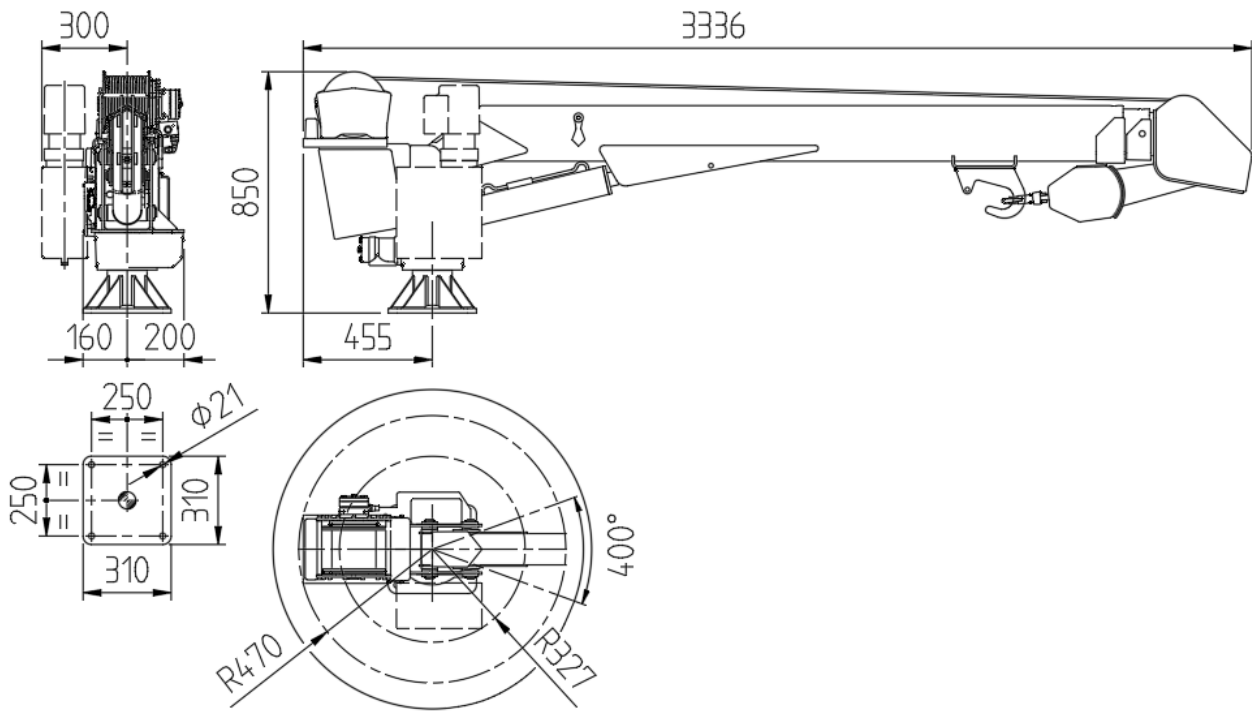

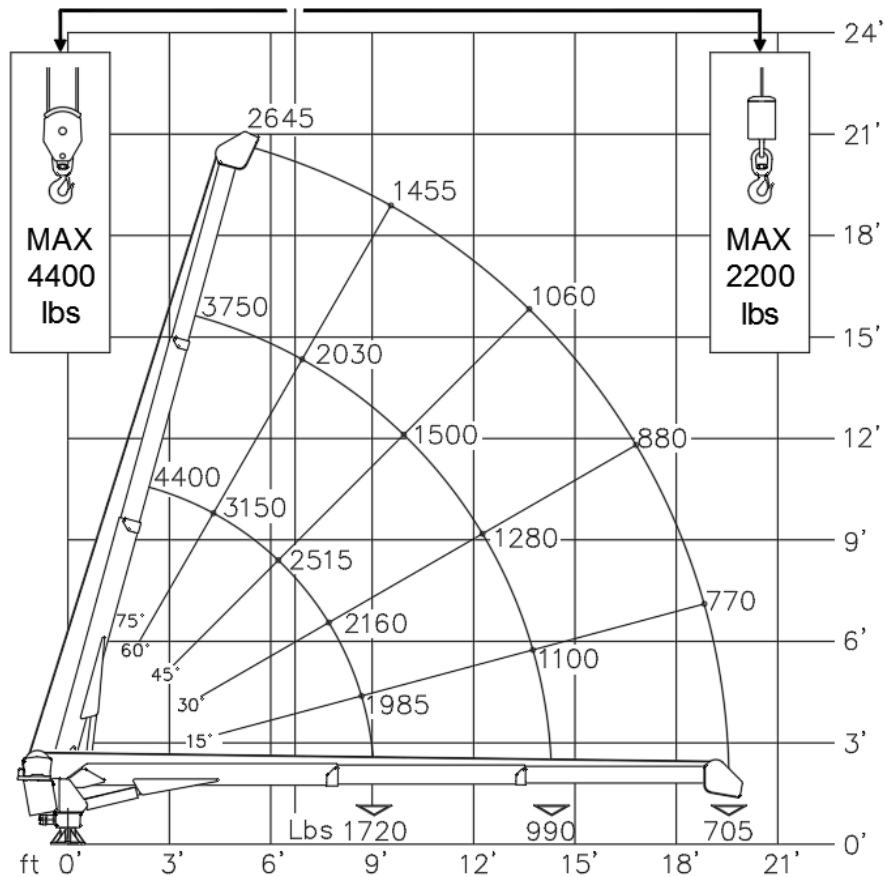
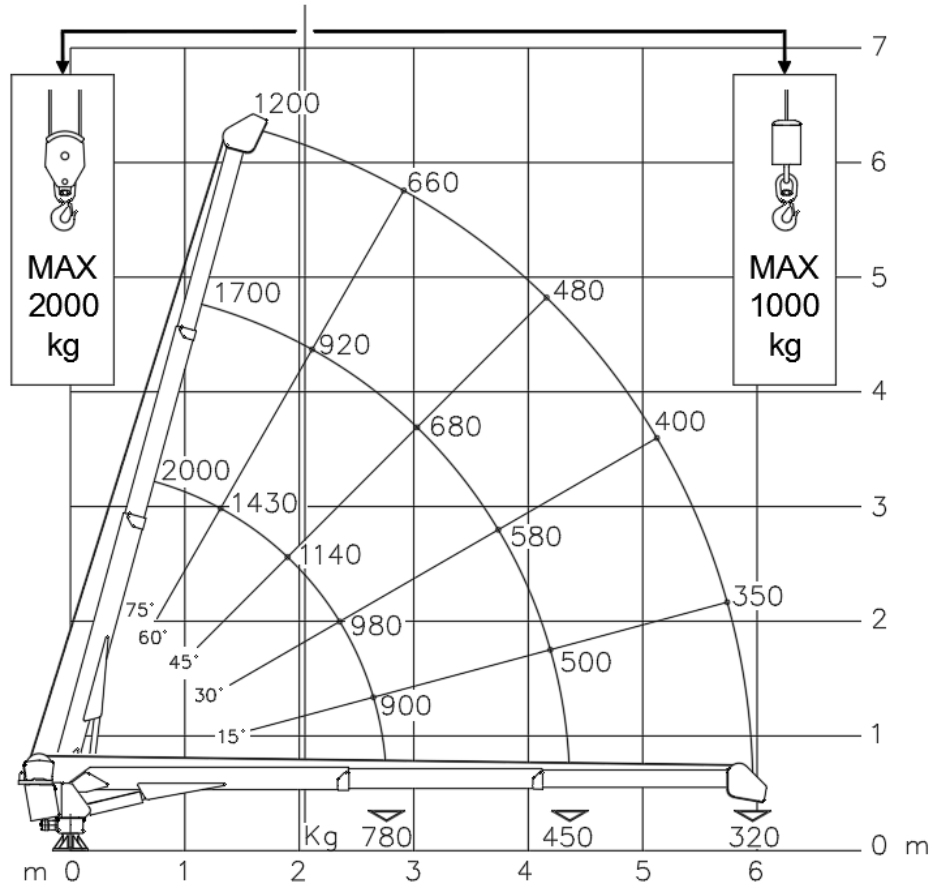

TECHNICAL DATA		Cobra 4400L (20 ft)	
VERSION		4400L.1	4400L.2
CRANE RATING	kNm ft.lbs	22 16000	
EXTENSIONS TYPE		1 HYDR. + 1 MANUAL	2 HYDRAULIC
HYDRAULIC EXTENSION	m ft	1.6 5' 3"	3.2 10' 6"
MANUAL EXTENSION	m ft	1.6 5' 3"	-
HORIZONTAL REACH (from center line of rotation)	m ft	6.03 19' 9"	
LIFTING HEIGHT FROM BASE OF CRANE	m ft	6 20'	
SLEWING ANGLE	°	400°	
SLEWING TORQUE	kNm ft.lbs	2.2 1600	
BOOM ELEVATION ANGLE	°	-5° / +75°	
MAX. WORKING PRESSURE	bar psi	195 2830	
SUGGESTED OIL FLOW (H version)	l/min gpm	10 2.7	
CRANE WEIGHT (H version)	kg lbs	355 785	375 825
CRANE WEIGHT (E version)	kg lbs	375 825	395 870

WINCH SPECIFICATIONS			
WINCH SINGLE LINE CAPACITY (1 <sup>ST</sup> layer)	kg lbs	1000 2200	
WINCH SINGLE LINE CAPACITY (3 <sup>RD</sup> layer)	kg lbs	880 1940	
WINCH PULL LINE SPEED (3 <sup>RD</sup> layer – H version)	m/min ft/min	12 40	
WINCH PULL LINE SPEED (3 <sup>RD</sup> layer – E version)	m/min ft/min	7 - 11 23 - 36	
WIRE ROPE DIAMETER	mm in	8 5/16"	
WIRE ROPE LENGTH	m ft	30 98' 5"	