

maxilift 12000 cobra

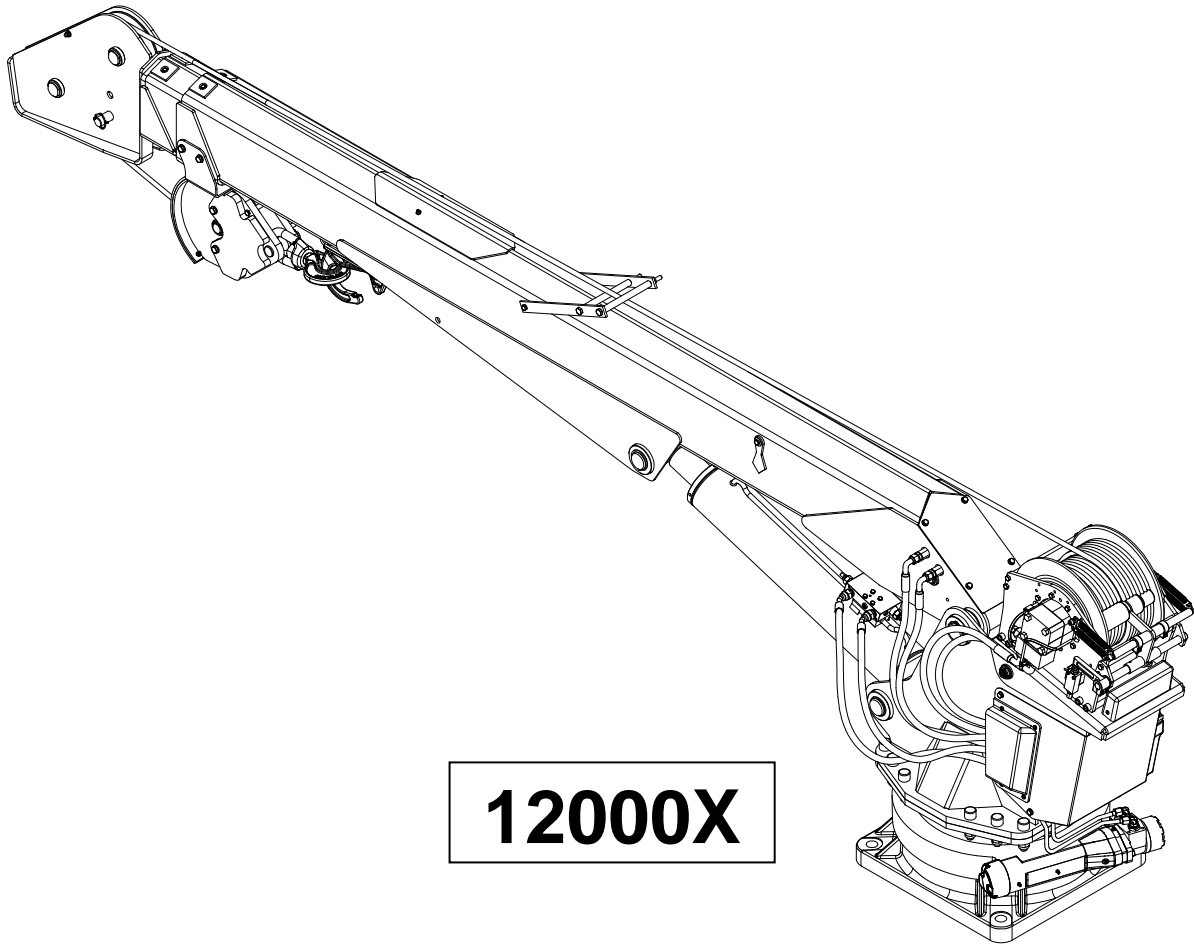

12000X

TECHNICAL SHEET

MP.0.219
Rev. 1



Next Hydraulics[®]
RAISE YOUR EXPECTATIONS

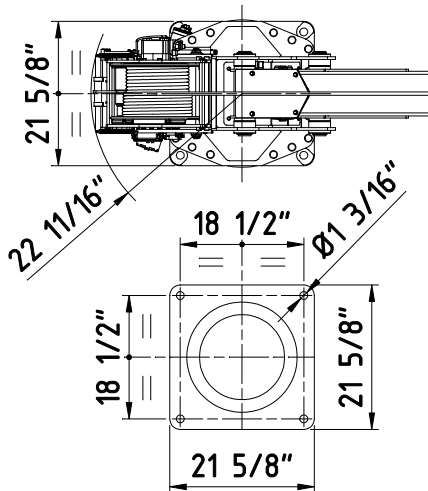
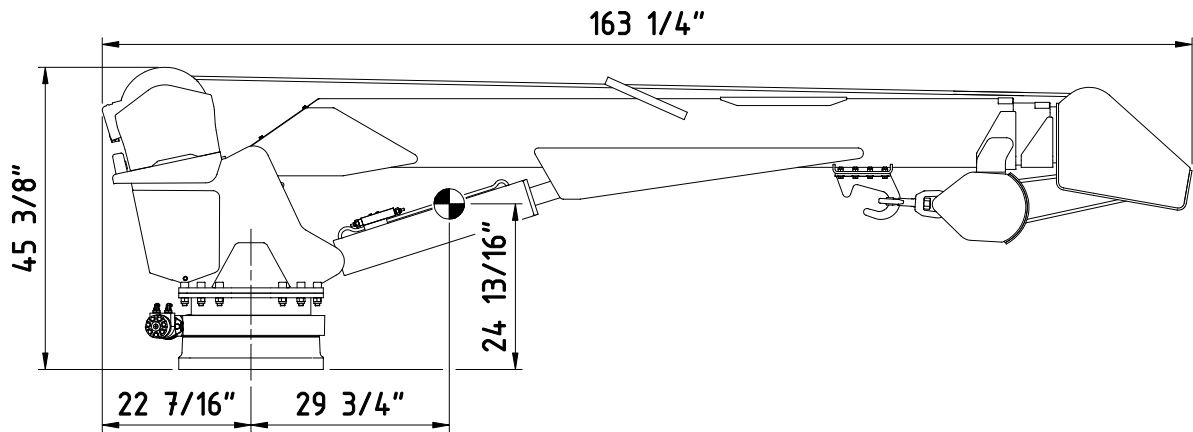
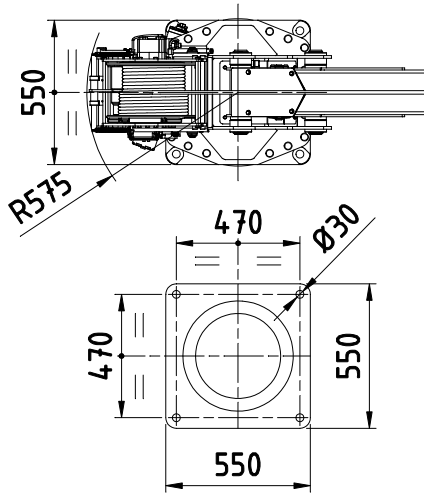
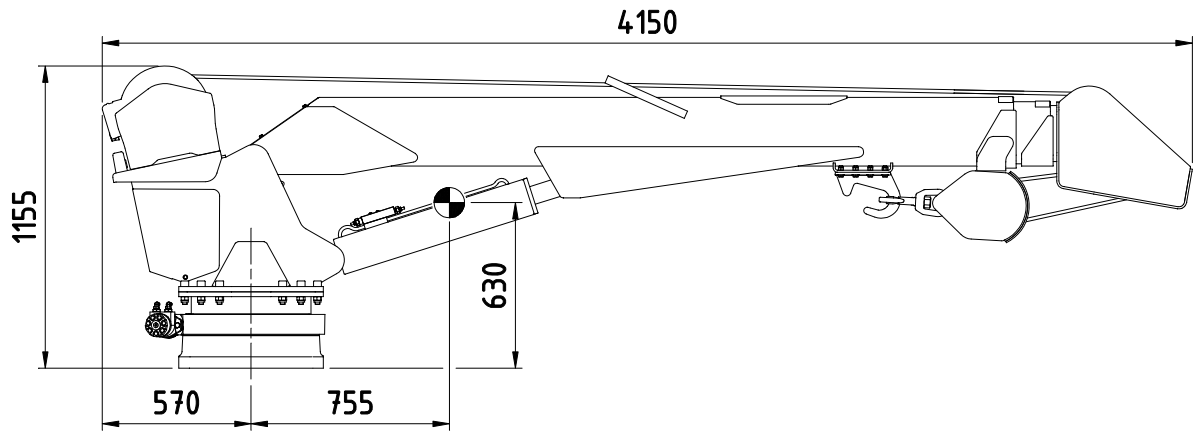

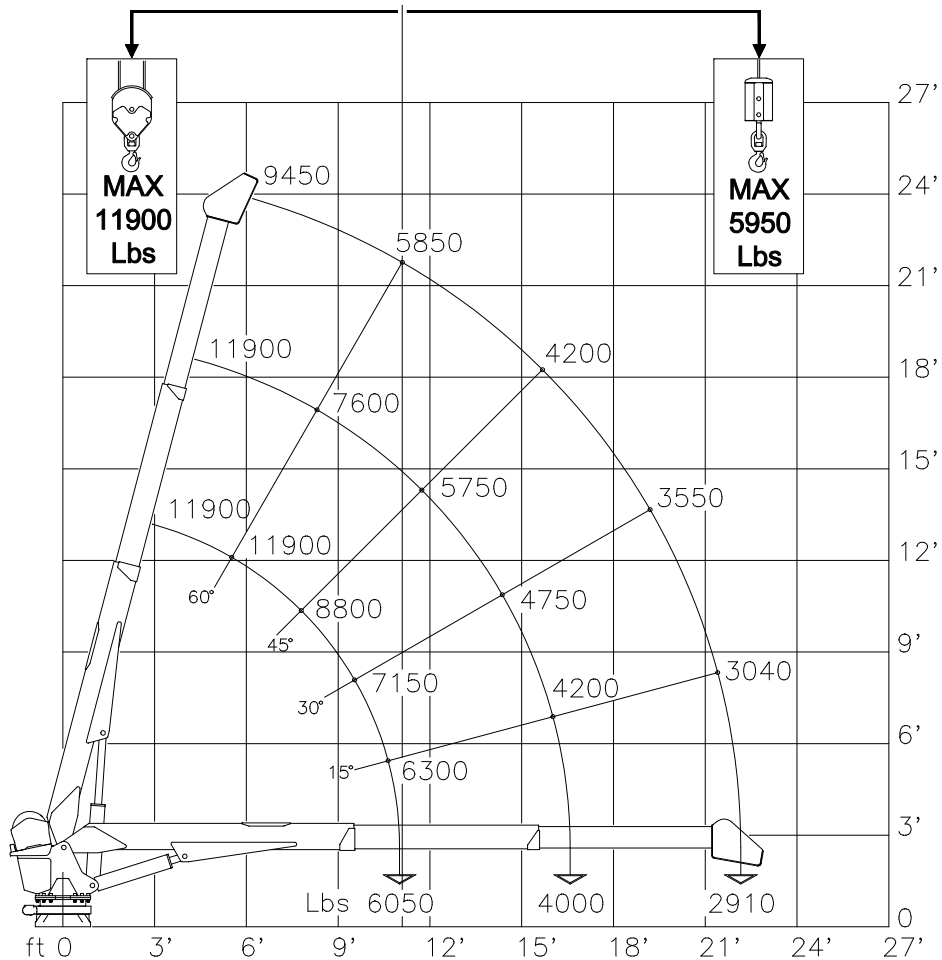
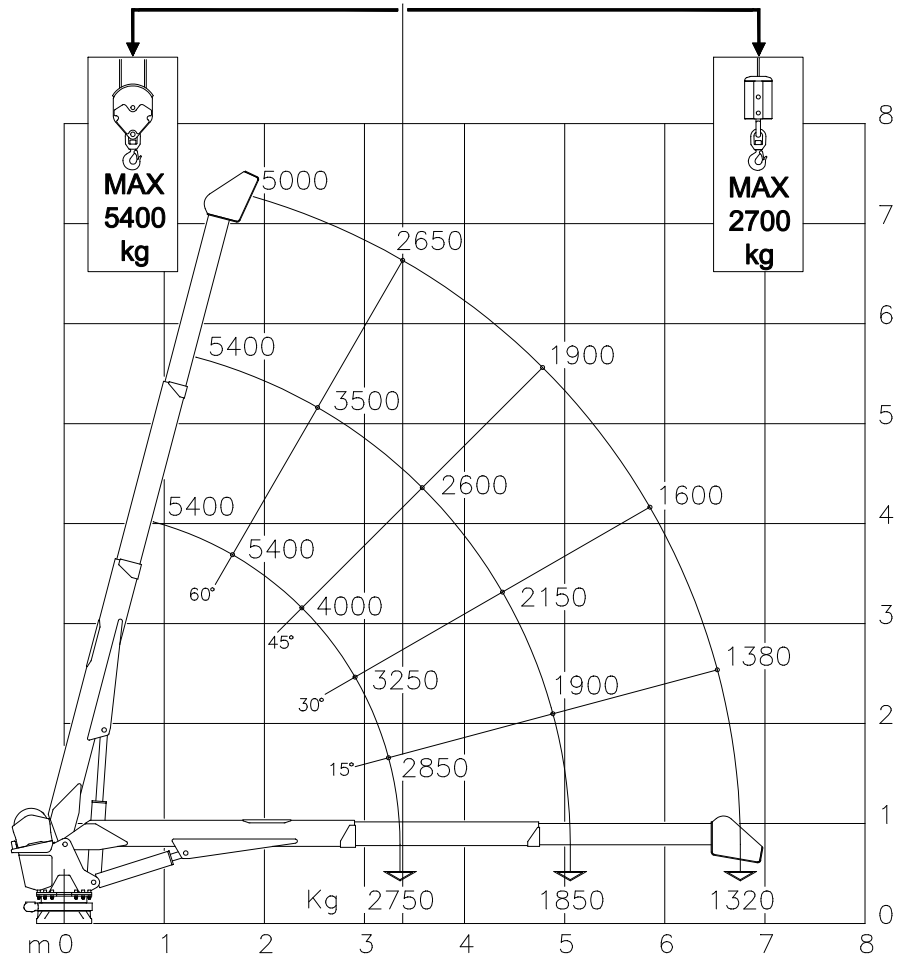

TECHNICAL DATA		Cobra 12000X
CRANE RATING	kNm ft.lbs	90.2 66500
EXTENSIONS TYPE		2 HYDRAULIC
HYDRAULIC EXTENSION	m ft	3.4 11' 2"
HORIZONTAL REACH (from center line of rotation)	m ft	6.8 22' 4"
LIFTING HEIGHT FROM BASE OF CRANE	m ft	7 23'
SLEWING ANGLE	°	CONTINUOUS
SLEWING TORQUE	kNm ft.lbs	9 6640
BOOM ELEVATION ANGLE	°	-10°/ +75°
MAX. WORKING PRESSURE	bar psi	210 3045
SUGGESTED OIL FLOW	l/min gpm	25 6.5
CRANE WEIGHT	kg lbs	970 2140

WINCH SPECIFICATIONS		
WINCH SINGLE LINE CAPACITY (1 ST layer)	kg lbs	3050 6720
WINCH SINGLE LINE CAPACITY (3 RD layer)	kg lbs	2450 5400
WINCH PULL LINE SPEED (2 ND -3 RD layer)	m/min ft/min	11 - 13 36 - 42
WIRE ROPE DIAMETER	mm in	12 1/2"
WIRE ROPE LENGTH	m ft	35 115'